



Features

- Up to 95% Efficiency
- Current Mode Operation for Excellent Line and Load Transient Response
- 700mA Output Current
- Low Quiescent Current: 200 μ A
- Output Voltage: 0.6V ~ 5.5V
- Automatic PWM/PFM Mode Switching
- No Schottky Diode Required
- Frequency Operation: 1.0MHz for Fixed Output Voltage and 1.4MHz for Adjustable Output Voltage
- Short-Circuit Protection
- Shutdown Quiescent Current: <1 μ A
- Low Profile TSOT/ SOT-23-5L Package (lead-free packaging is now available)

Applications

- Digital cameras and MP3
- Palmtop computers / PDAs
- Cellular phones
- Wireless handsets and DSL modems
- Portable media players
- PC cards

Description

The HX1001 is high efficiency synchronous, PWM step-down DC/DC converters working under an input voltage range from 2.2V to 5.5V. This feature makes the HX1001 suitable for single Li-Ion battery-powered applications. 100% duty cycle capability extends battery life in portable devices, while the quiescent current is 200 μ A with no load, and drops to <1 μ A in shutdown.

The internal synchronous switch is desired to increase efficiency without an external Schottky diode. The 1.0MHz/1.4MHz switching frequency allows the using of tiny, low profile inductors and ceramic capacitors, which minimized overall solution footprint.

The HX1001 converters are available in the industry standard TSOT/SOT-23-5L power packages (or upon request).

Order Information

HX1001 – ① ② ③:

SYMBOL	DESCRIPTION
①	Denotes Output Voltage: A: Adj K: 1.2V B: 1.5 V C: 1.8V G: 3.3V
②	Denotes Package Type: E: SOT-23-5L
③	Internal Definition

Note: Only suitable for three-suffix letter products. Except HX1001-AETC, the “ET” means TSOT-23-5L Packages and the “C” is defined by internal.

Typical Application Circuit

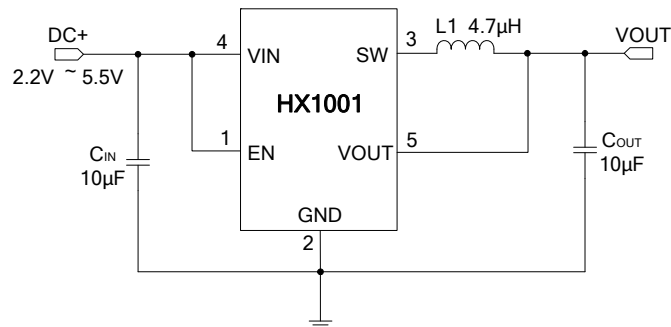
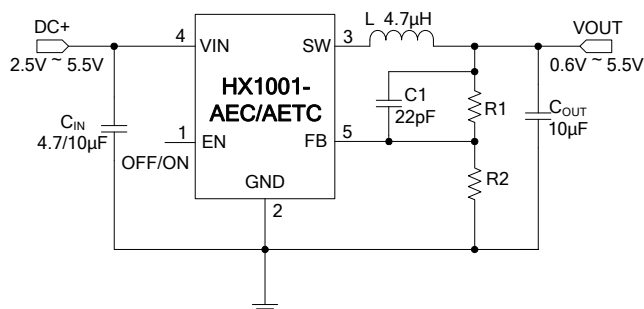

Figure 1: Fixed Voltage Converter



$$*V_{OUT} = 0.6V \cdot [1 + (R1/R2)].$$

Figure 2: Adjustable Voltage Converter

Model	VOUT (V)	VIN (V)
HX1001-AEC	0.6 ~ 5.5	2.5 ~ 5.5
HX1001-AETC	0.6 ~ 5.5	2.5 ~ 5.5
HX1001-KEC	1.2	2.2 ~ 5.5
HX1001-BEC	1.5	2.5 ~ 5.5
HX1001-CEC	1.8	2.5 ~ 5.5
HX1001-GEC	3.3	3.4 ~ 5.5

Pin Assignment and Description

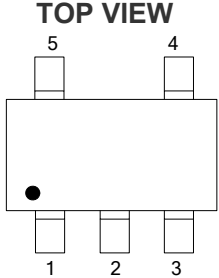
 TOP VIEW TSOT/SOT-23-5L	PIN	NAME	DESCRIPTION
	1	EN	ON/OFF Control(High Enable)
2	GND	Ground	
3	SW	Switch Output	
4	VIN	Power Input	
5	VOUT/FB	Feedback	

Absolute Maximum Ratings (Note 1)

- Power Dissipation.....Internally limited
- Input Voltage.....-0.3V ~ +6V
- Output Voltage.....-0.3V ~ +6V
- EN,SW Pin Voltage.....-0.3V ~ (V_{IN}+0.3)V
- SW Pin Current.....1.3A
- Operating Temperature Range(Note 2)-40°C ~ +85°C
- Junction Temperature-40°C ~ +125°C
- Storage Temperature Range-65°C ~ +150°C
- Lead Temperature (Soldering,10 sec.)+265°C

Note 1: Stresses listed as the above “Absolute Maximum Ratings” may cause permanent damage to the device. Exposure to absolute maximum rating conditions for extended periods may remain possibility to affect device reliability.

Note 2: The HX1001 is guaranteed to meet performance specifications from 0°C to 85°C. Specifications over the -40°C to 85°C operating temperature range are assured by design, characterization and correlation with statistical process controls.

Electrical Characteristics

Operating Conditions: $T_A=25^{\circ}\text{C}$, $V_{IN} = V_{OUT} + 1\text{V}$, unless otherwise specified.

SYMBOL	PARAMETER	CONDITIONS	MIN	TYP	MAX	UNITS
V_{IN}	Input Voltage		2.2		5.5	V
ΔV_{OUT}	Output Voltage Accuracy (For Fixed Output Voltage)	$I_{OUT}=100\text{mA}$	-2		+2	%
V_{OUT}	Adjustable Output Range		0.6		5.5	V
V_{FB}	Regulated Voltage	$T_A = 25^{\circ}\text{C}$	0.588	0.6	0.612	V
ΔV_{FB}	V_{REF}	$V_{IN}=2.5\text{V} \sim 5.5\text{V}$		0.03	0.4	%/V
I_{FB}	Feedback Current				± 30	nA
I_Q	Quiescent Current	$V_{FB} = 0.5\text{V}$ or $V_{OUT} = 90\%$, $I_{LOAD} = 0\text{A}$		200		μA
I_{SHTD}	Shutdown Current	$V_{EN}=0\text{V}$, $V_{IN}=4.2\text{V}$, For Fixed Output Voltage		0.1	1	μA
		$V_{EN}=0\text{V}$, $V_{IN}=5\text{V}$, For Adjustable Output Voltage		0.5	1	μA
f_{OSC}	Oscillator Frequency	$V_{OUT}=100\%$, For Fixed Output Voltage		1.0		MHz
		$V_{FB}=0.6\text{V}$, For Adjustable Output Voltage		1.4		MHz
I_{PK}	Peak Inductor Current	$V_{FB}=0.5\text{V}$ or $V_{OUT}= 90\%$	0.75	0.9	1.1	A
R_{PFET}	$R_{DS(ON)}$ of P-Channel FET	$I_{SW}=100\text{mA}$		0.3		Ω
R_{NFET}	$R_{DS(ON)}$ of N-Channel FET	$I_{SW}=-100\text{mA}$		0.39		Ω
ΔV_{LINE}	V_{OUT} Line Regulation	$V_{IN}=(V_{OUT}+0.5)$ to 5.5V		0.03	0.3	%/V
ΔV_{LOAD}	V_{OUT} Load Regulation	$0\text{mA} \leq I_{OUT} \leq 100\text{mA}$		0.33		%
EFFI	Efficiency	When connected to extra components , $V_{IN}=V_{EN}=2.7\text{V}$, $V_{OUT}=2.5\text{V}$, $I_{OUT}=100\text{mA}$		90	95	%

Typical Performance Characteristics

**Efficiency vs. Output Current
(Vout=1.2V)**

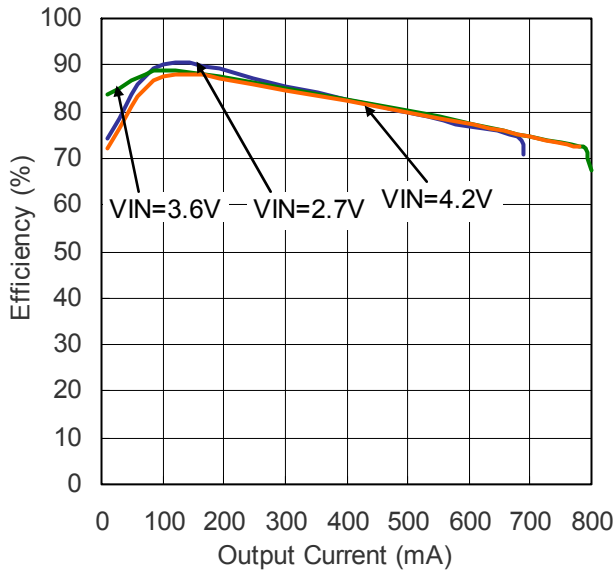

**Output Voltage vs. Load Current
(Vin=3.6V, Vout=1.2V)**

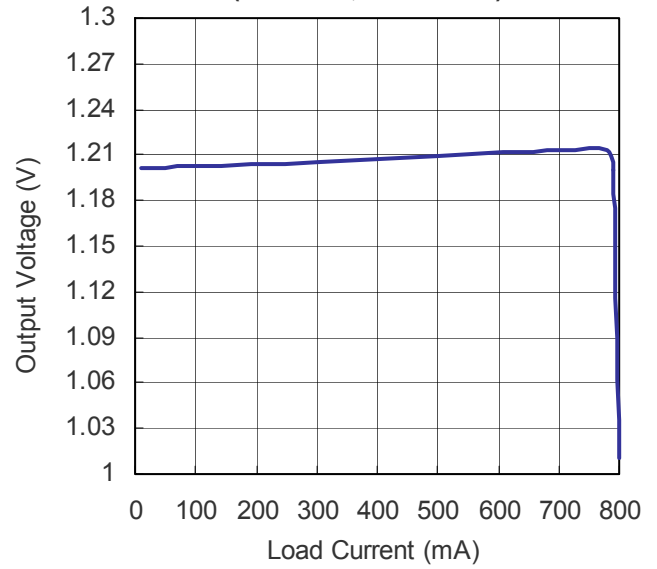

**Efficiency vs. Output Current
(Vout=1.8V)**

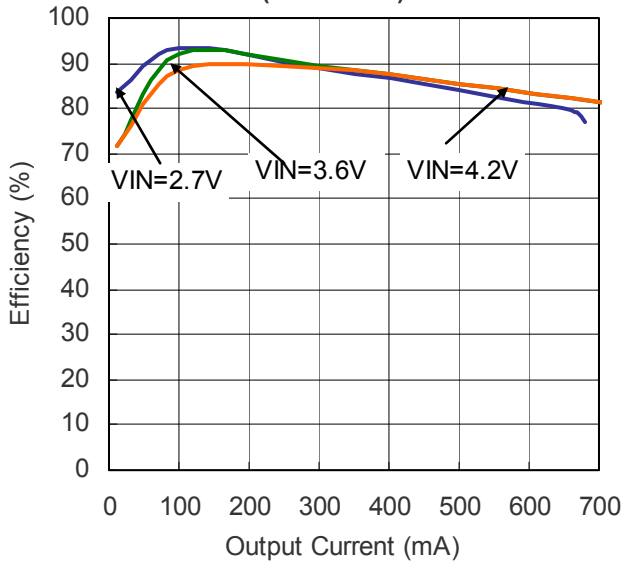

**Output Voltage vs. Load Current
(Vin=3.6V, Vout=1.8V)**

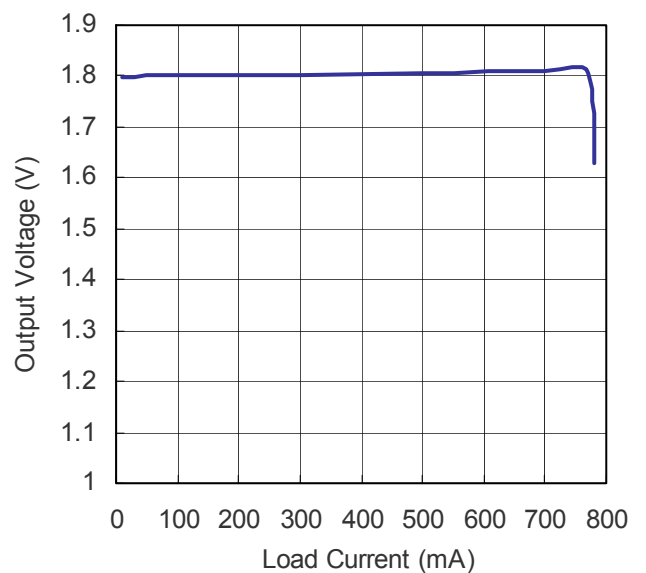

Supply Current vs. Supply Voltage
($V_{out}=1.8V$ $I_o=0A$)

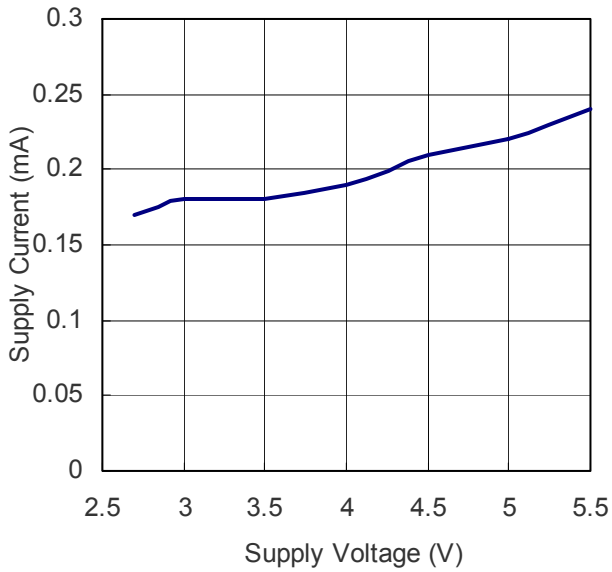

Start-up from Shutdown
(1.00V/div 1.00V/div 100 μ s/div)

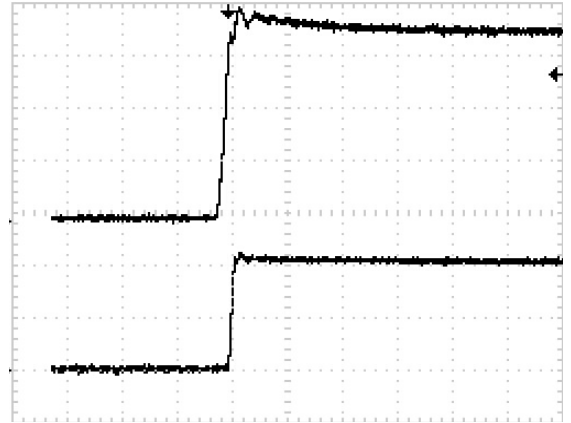

$V_{IN}=3.6V$ $V_{OUT}=1.8V$ $I_{LOAD}=0mA$

Output Noise (10mV/DIV 200ns/DIV
AC COUPLED)

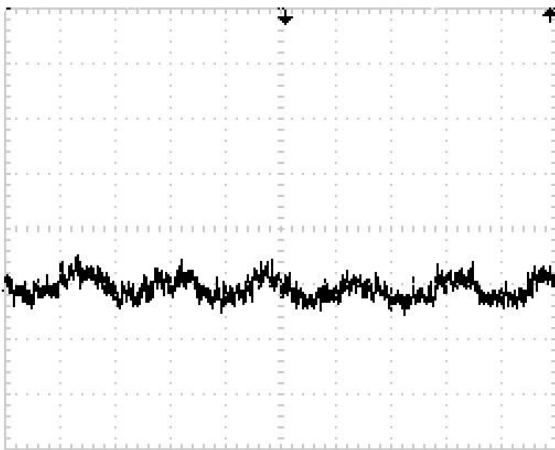

$V_{IN}=3.6V$ $V_{OUT}=1.8V$ $I_{LOAD}=200mA$

Output Noise (100mV/DIV 2ms/DIV
AC COUPLED)

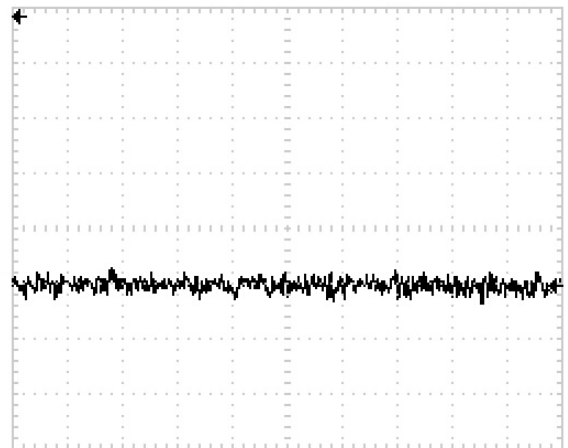

$V_{IN}=3.6V$ $V_{OUT}=1.8V$ $I_{LOAD}=0mA$

Pin Functions

EN (Pin 1): En Control Input. Forcing this pin above 1.5V enables the part. Forcing this pin below 0.6V can shut down the device. In shutdown, all functions are disabled drawing <math><1\mu\text{A}</math> supply current. Do not leave EN floating.

GND (Pin 2): Ground Pin.

SW (Pin 3): Switch Node Connection to Inductor. This pin connects to the drains of the internal main and synchronous power MOSFET switches.

VIN (Pin 4): Main Supply Pin. A 10 μF ceramic VIN capacitor recommended must be closely decoupled to GND.

VOUT/FB (Pin 5): Feedback Pin. In the nonadjustable version, the output voltage is fixed. In the adjustable version, the FB pin receives the feedback voltage from an external resistive divider across the output. The output voltage is set by a resistive divider according to the following formula: $V_{\text{OUT}} = 0.6\text{V} \cdot [1 + (R1/R2)]$.

Application Information

The basic HX1001 application circuit is shown in Typical Application Circuit. External component selection is determined by the maximum load current and begins with the selection of the inductor value and operating frequency followed by C_{IN} and C_{OUT} .

Inductor Selection

For most applications, the value of the inductor will fall in the range of $1\mu\text{H}$ to $4.7\mu\text{H}$. Its value is chosen based on the desired ripple current. Large value inductors lower ripple current and small value inductors result in higher ripple currents. Higher V_{IN} or V_{OUT} also increases the ripple current as shown in the equation. A reasonable starting point for setting ripple current is $\Delta I_L = 280\text{mA}$ (40% of 700mA).

$$\Delta I_L = \frac{1}{(f)(L)} V_{OUT} \left(1 - \frac{V_{OUT}}{V_{IN}} \right)$$

The DC current rating of the inductor should be at least equal to the maximum load current plus half the ripple current to prevent core saturation. Thus, a 840mA rated inductor should be enough for most applications (700mA + 140mA). For better efficiency, choose a low DC-resistance inductor.

Different core materials and shapes will change the size/current and price/current relationship of an inductor. Toroid or shielded pot cores in ferrite or perm alloy materials are small and don't radiate much energy, but generally cost more than powdered iron core inductors with similar electrical characteristics. The choice of which style inductor to use often depends more on the price vs. size requirements and any radiated field/EMI requirements than on what the HX1001 requires to operate.

Output and Input Capacitor Selection

In continuous mode, the source current of the top MOSFET is a square wave of duty cycle V_{OUT}/V_{IN} . To prevent large voltage transients, a low ESR input capacitor sized for the maximum RMS current must be used. The maximum RMS capacitor current is given by:

$$C_{IN} \text{ required } I_{RMS} \cong I_{OMAX} \frac{[V_{OUT}(V_{IN} - V_{OUT})]^{1/2}}{V_{IN}}$$

This formula has a maximum at $V_{IN} = 2V_{OUT}$, where $I_{RMS} = I_{OUT}/2$. This simple worst-case condition is commonly used for design because even significant deviations do not offer much relief. Note that the capacitor manufacturer's ripple current ratings are often based on 2000 hours of life. This makes it advisable to further derate the capacitor, or choose a capacitor rated at a higher temperature than required. Always consult the manufacturer if there is any question.

The selection of C_{OUT} is driven by the required effective series resistance (ESR).

Typically, once the ESR requirement for C_{OUT} has been met, the RMS current rating generally far exceeds the $I_{RIPPLE(P-P)}$ requirement. The output ripple ΔV_{OUT} is determined by:

$$\Delta V_{OUT} \cong \Delta I_L \left(\text{ESR} + \frac{1}{8fC_{OUT}} \right)$$

Where f = operating frequency, C_{OUT} = output capacitance and ΔI_L = ripple current in the inductor. For a fixed output voltage, the output ripple is highest at maximum input voltage since ΔI_L increases with input voltage.

Aluminum electrolytic and dry tantalum capacitors are both available in surface mount configurations. In the case of tantalum, it is critical that the capacitors are surge tested for use in switching power supplies. An excellent choice is the AVX TPS series of surface mount tantalum. These are specially constructed and tested for low ESR so they give the lowest ESR for a given volume. Other capacitor types include Sanyo POSCAP, Kemet T510 and T495 series, and Sprague 593D and 595D series. Consult the manufacturer for other specific recommendations.

Efficiency Considerations

The efficiency of a switching regulator is equal to the output power divided by the input power times 100%. It is often useful to analyze individual losses to determine what is limiting the efficiency and which change would produce the most improvement. Efficiency can be expressed as: Efficiency = 100% - (L1+ L2+ L3+ ...) where L1, L2, etc. are the individual losses as a percentage of input power. Although all dissipative elements in the circuit produce losses, two main sources usually account for most of the losses: VIN quiescent current and I^2R losses. The VIN quiescent current loss dominates the efficiency loss at very low load currents whereas the I^2R loss dominates the efficiency loss at medium to high load currents. In a typical efficiency plot, the efficiency curve at very low load currents can be misleading since the actual power lost is of no consequence.

1. The VIN quiescent current is due to two components: the DC bias current as given in the electrical characteristics and the internal main switch and synchronous switch gate charge currents. The gate charge current results from switching the gate capacitance of the internal power MOSFET switches. Each time the gate is switched from high to low to high again, a packet of charge ΔQ moves from VIN to ground. The resulting $\Delta Q/\Delta t$ is the current out of VIN that is typically larger than the DC bias current. In continuous mode, $I_{GATECHG} = f(Q_T + Q_B)$ where Q_T and Q_B are the gate charges of the internal top and bottom switches. Both the DC bias and gate charge losses are proportional to VIN and thus their effects will be more pronounced at higher supply voltages.

2. I^2R losses are calculated from the resistances of the internal switches, R_{SW} and external inductor R_L . In continuous mode the average output current flowing through inductor L is “chopped” between the main switch and the synchronous switch. Thus, the series resistance looking into the SW pin is a function of both top and bottom MOSFET $R_{DS(ON)}$ and the duty cycle (DC) as follows: $R_{SW} = R_{DS(ON)TOP} \times DC + R_{DS(ON)BOT} \times (1-DC)$ The $R_{DS(ON)}$ for both the top and bottom MOSFETs can be obtained from the Typical Performance Characteristics curves. Thus, to obtain I^2R losses, simply add R_{SW} to R_L and multiply the result by the square of the average output current. Other losses including C_{IN} and C_{OUT} ESR dissipative losses and inductor core losses generally account for less than 2% of the total loss.

PCB Layout Guidelines

When laying out the printed circuit board, the following checklist should be used to ensure proper operation of the HX1001. Check the following in your layout:

1. The power traces, consisting of the GND trace, the SW trace and the VIN trace should be kept short, direct and wide.
2. Put the input capacitor as close as possible to the device pins (VIN and GND).
3. SW node is with high frequency voltage swing and should be kept small area. Keep analog components away from SW node to prevent stray capacitive noise pick-up.
4. Connect all analog grounds to a command node and then connect the command node to the power ground behind the output capacitors.
5. Keep the (-) plates of C_{IN} and C_{OUT} as close as possible.

Packaging Information

SOT-23-5L Package Outline Dimension

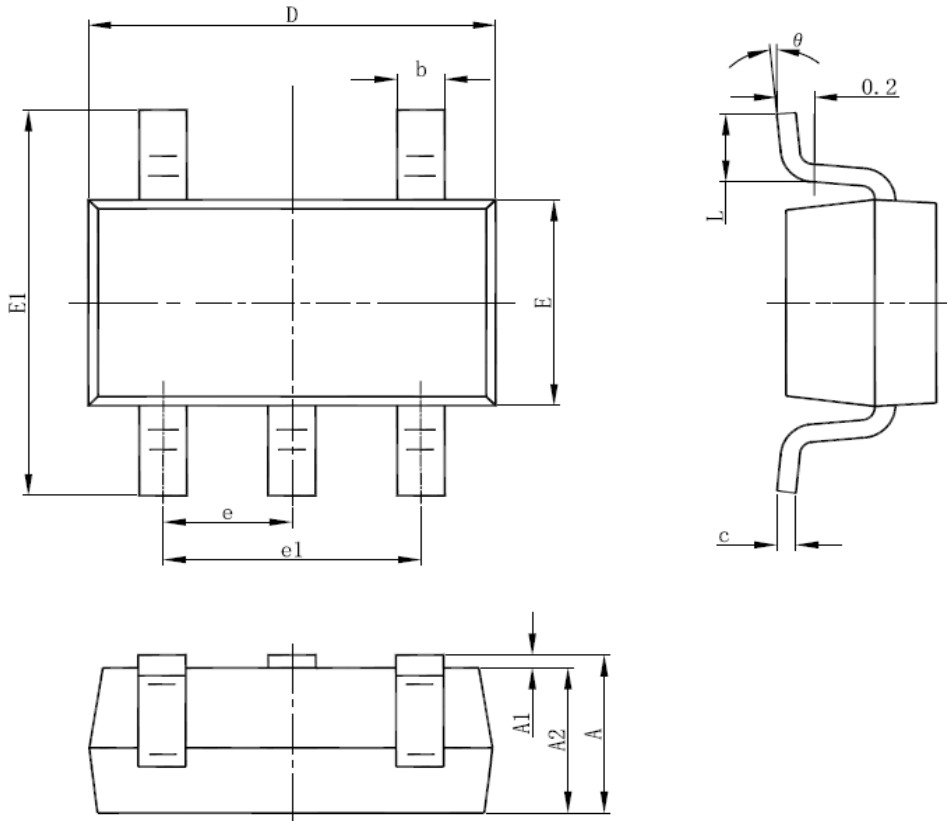

Symbol	Dimensions In Millimeters		Dimensions In Inches	
	Min	Max	Min	Max
A	1.050	1.250	0.041	0.049
A1	0.000	0.100	0.000	0.004
A2	1.050	1.150	0.041	0.045
b	0.300	0.500	0.012	0.020
c	0.100	0.200	0.004	0.008
D	2.820	3.020	0.111	0.119
E	1.500	1.700	0.059	0.067
E1	2.650	2.950	0.104	0.116
e	0.950(BSC)		0.037(BSC)	
e1	1.800	2.000	0.071	0.079
L	0.300	0.600	0.012	0.024
θ	0°	8°	0°	8°

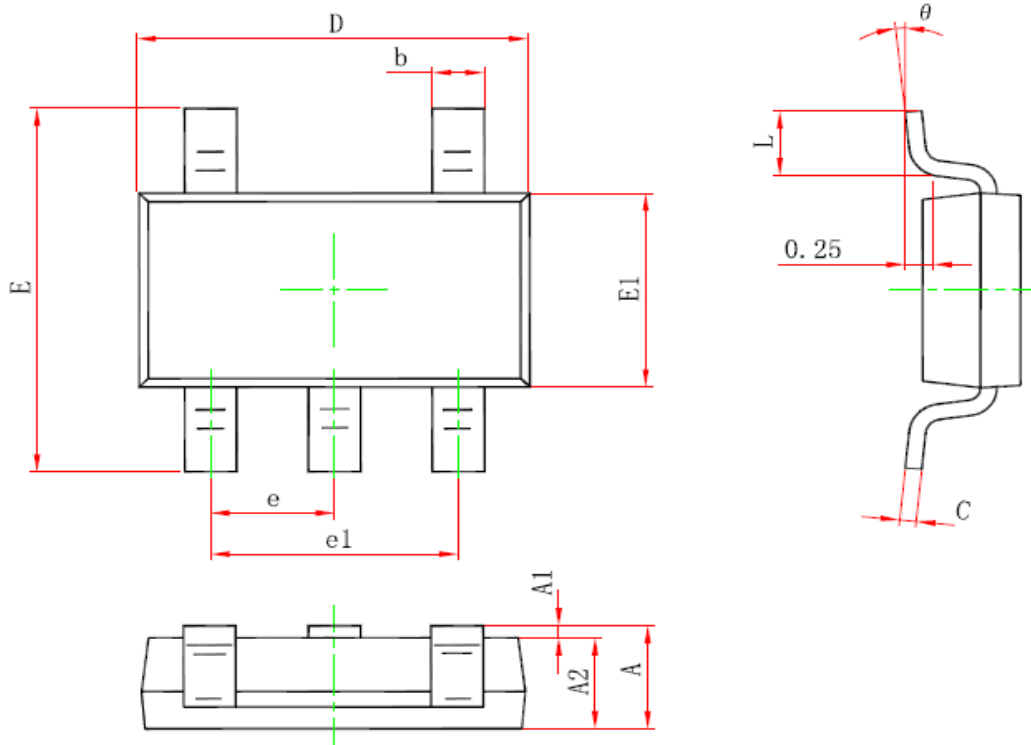
TSOT-23-5L Package Outline Dimension

Symbol	Dimensions In Millimeters		Dimensions In Inches	
	Min	Max	Min	Max
A	---	0.900	---	0.035
A1	0.020	0.090	0.001	0.004
A2	0.700	0.800	0.028	0.031
b	0.350	0.500	0.014	0.020
c	0.080	0.200	0.003	0.008
D	2.820	3.020	0.111	0.119
E1	1.600	1.700	0.063	0.067
E	2.650	2.950	0.104	0.116
e	0.95 (BSC)		0.037(BSC)	
e1	1.90 (BSC)		0.075(BSC)	
L	0.300	0.600	0.012	0.024
θ	0°	8°	0°	8°

Subject changes without notice